



DRY AGER

BUILT FOR BEEF

DX500 Smart Ager
Technical Specifications



Dry Aging has never been easier: With SmartAging®

The perfect result at the touch of a button.

Because you don't want the meat to shiver, but instead to age, the new generation of DRY AGER® Dry Aging Fridges, promises success - plain and simple.

Now we have more than just beef on the menu: SmartAging® can be used to dry age a wide variety of foods.

And because you certainly don't want to make any mistakes, now your worries are over. Because now you can be sure that you have the right parameters at hand for the aging process of any food: at the push of a button.

You just select the appropriate dry aging program via the new control system directly on the DRY AGER® Dry Aging Fridge, and off you go.



Model	SKU
DX500 Stainless Steel Smart Ager	55805SA
DX500 Black Edition Smart Ager	55805BSA





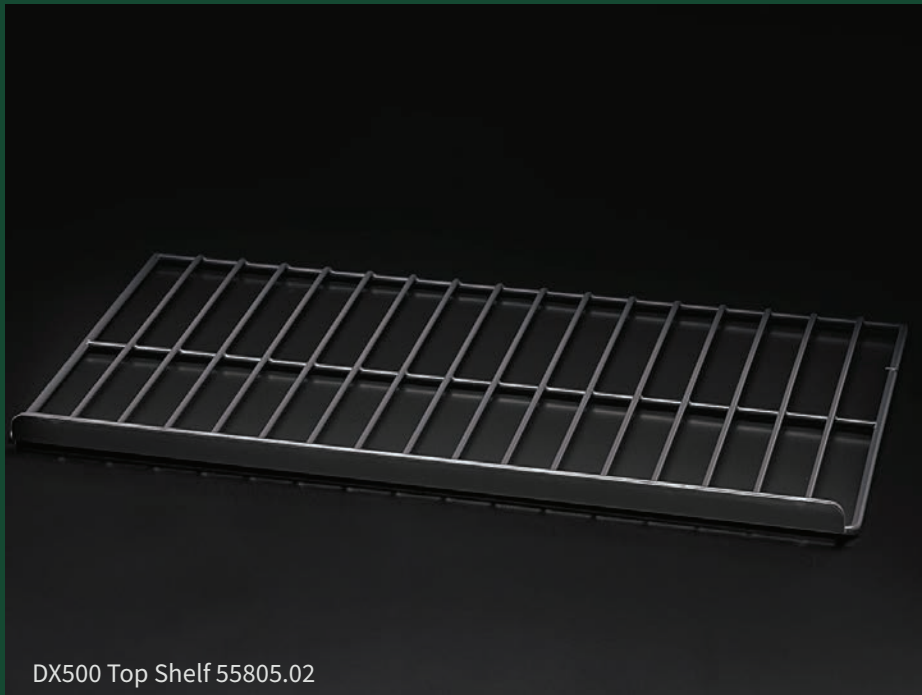

DX500 Top Shelf 55805.02

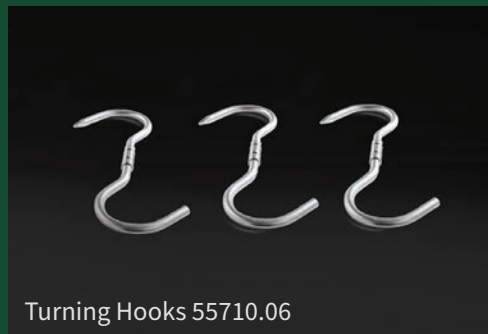

Turning Hooks 55710.06



Dry Aging Book 55910.01



UVC Bulb & Carbon Filter



Apron 55910.02



DX500 Hanger Bar 55805.01



Special Cleaner 55710.13



Himalayan Salt Block Set of Two 55705.04



Steak Pan 55710.25

DRY AGER™ DX500 Premium Smart Ager

SKU	Product
55805SA	DX500 Smart Ager Stainless Steel Includes top & bottom shelf
55805BSA	DX500 Smart Ager Black Edition Includes top & bottom shelf
55805.01	Hanger Bar
55805.02	Top Shelf
55805.03	Salami Shelf
55705.04	Himalayan Salt Block Set
55705.05	Stainless Steel Drip Tray
55705.06	Wall Mounting Kit
55710.13	Special Cleaner
55910.01	Dry Aging Book
55910.02	Apron
55710.25	Steak Pan
55710.29	UVC Bulb
55710.07	Carbon Filters



Stainless Steel Model Pictured

Technical Specifications

Housing	Black Powder Coated & Stainless Steel Door
Inner Container	Antibacterial Polystyrene
Inner Back Wall	Black Steel, Black Brushed Stainless Steel
Insulating Glass Door	UV Protection, Tinted (Metalised)
Internal Dimensions	712 x 490 x 437mm (H x W x D)
External Dimensions	905 x 600 x 610mm (H x W x D)
Ambient Temperature Range	Min. 1.0°C - Max. 32°C
Internal Capacity / Net	155 / 134L
Voltage	220 - 240V / 50Hz
Power Consumption	1.0kWh/24hr
Temperature Range	Electronically Adjustable in 0.1°C steps: 0°C to 30°C
Relative Humidity	Electronically Adjustable from 40 - 90% No water connection or tank required
Air Flow & Hygiene	Optimal Air Flow, Fresh-Air Activated Carbon Filter and UVC Sterilisation
SmartAging®	Enables Automated Aging Including Guaranteed Success
Interior Lighting	DX LED Premium Light Strips, Integrated Into Side Panels. No UV radiation. Minimal Heat Generation
Maximum Load	Up To 20kg Of Meat

Installation Dimensions

Front View

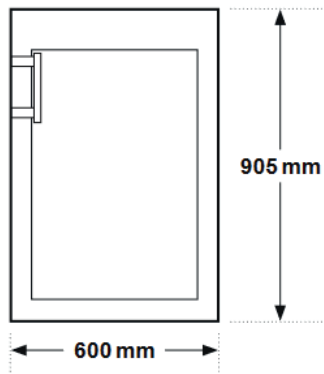

Top View

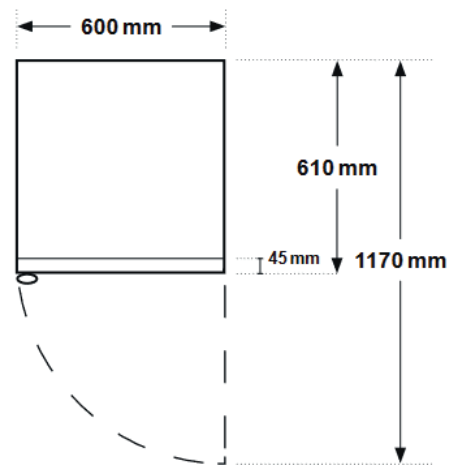

Wall Integration Drawings

Single Unit Installation

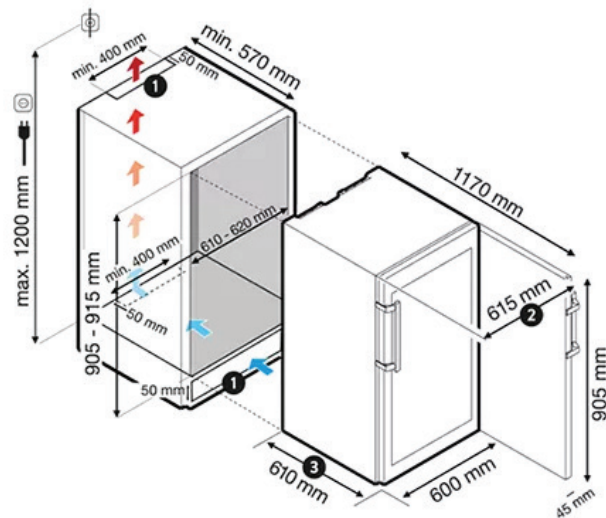

Side-by-Side Installation

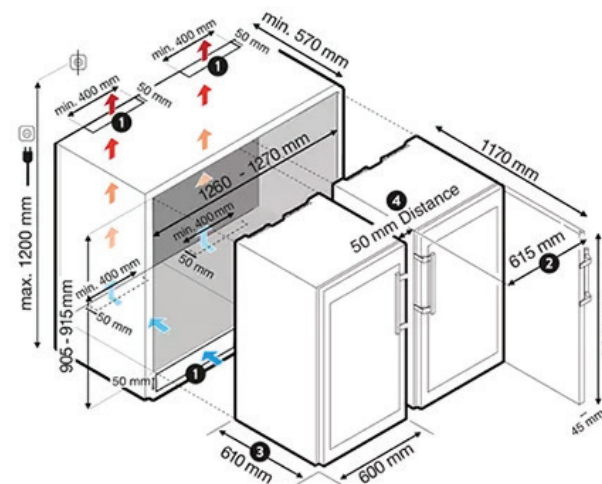

Now we
have more
than just
beef on
the menu.

DRY AGER™ Australia

1300 113 115

VIC | NSW | WA

dryager.com.au